

data sheet

model PMST2523

PERImax pump series™

Features

- 4 and 6 roller versions
- Heavy duty front and back ball bearings
- Robust direct drive 24 VDC NEMA 23 stepper motor
- Accepts 3 common tubing sizes without modification
- Perfect for dosing, dispensing and metering
- Change tubing in seconds without tools
- Can pump slurries with high particulate content
- Can pump fluid, gas or air
- Self-Priming and designed for panel mounting
- Fluid only contacts the inside of the tubing
- Excellent dry running characteristics
- Pumps extremely hot or cold fluids
- Large selection of options and modifications
- Compatible with many chemicals and aggressive fluids
- Motor controllers sold separately

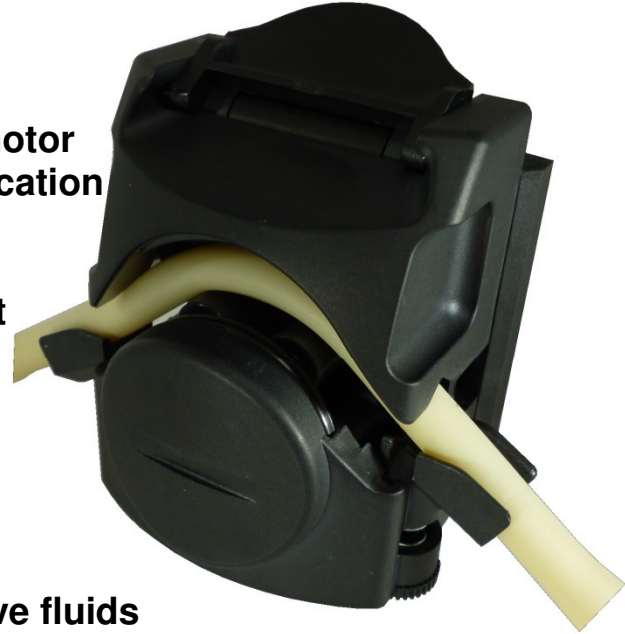

Dimensions

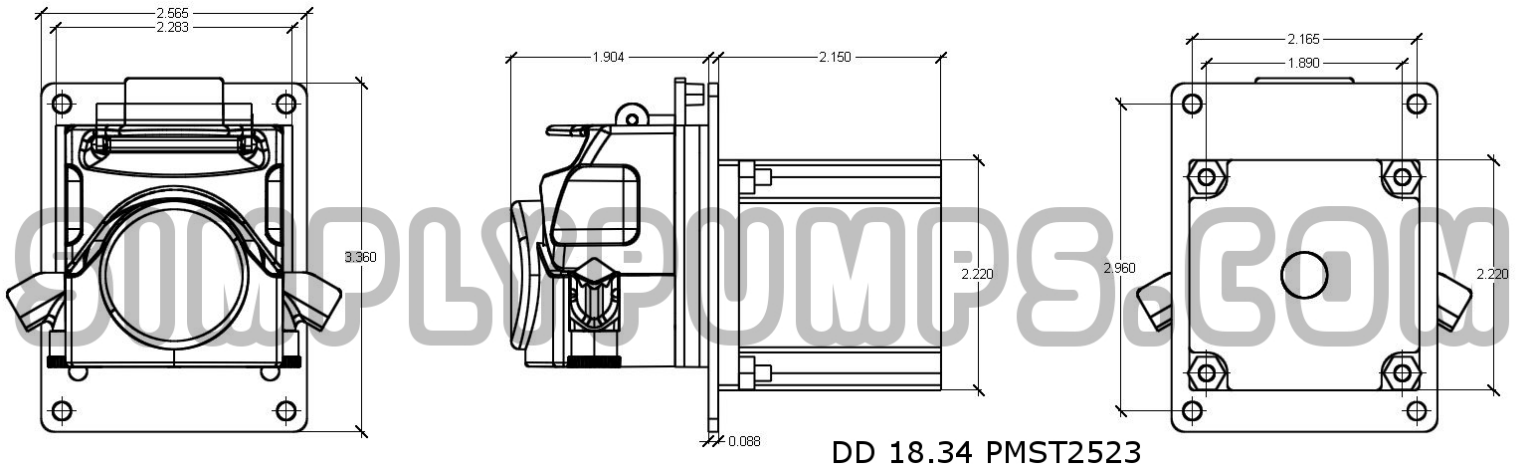

SimplyPumps.com™

724-864-5959

Specifications are subject to change without notice. No liability or warranty implied by this information.
Copyright © 2018 Simply Pumps Revised 2/9/19 R4

data sheet

model PMST2523

PERIMAX pump series™

Specifications

- 24 VDC - 1.50 amps - 18 watt
- See chart below for estimated flow rates
- Maximum pressure: 25 psi
- Maximum Suction Lift: 20 feet
- Dimensions: 4.825 x 2.560 x 3.365 inches
- Weight: 36 ounces



Generally, stepper motor driven pumps work best in very low flow applications. For this reason, the flow rates in the chart below are given in milliliters per revolution. The motor controller, tubing type and size, fluid viscosity, number of rollers, and back pressure will determine actual flow rate, psi and current consumption.

Tubing ID	Tubing OD	Our Tubing Part No	Flow Rate ml/rev
1/16 (0.0625)	3/16 (0.1875)	FT216	0.19
1/8 (0.125)	1/4 (0.2500)	FT203	0.66
3/16 (0.1875)	5/16 (0.3125)	FT200	1.25

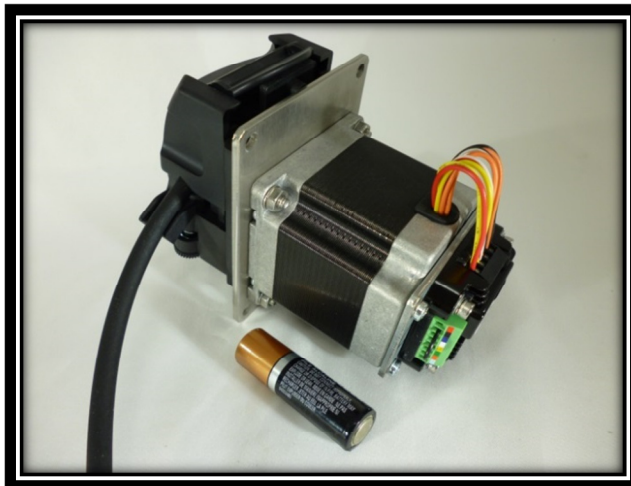

Simply Pumps™.com

724-864-5959